

MAC 2000 MOBILE AIR CONDITIONING

Instruction 2072-0400 Operation & Maintenance

Rev. 0 – March 2002

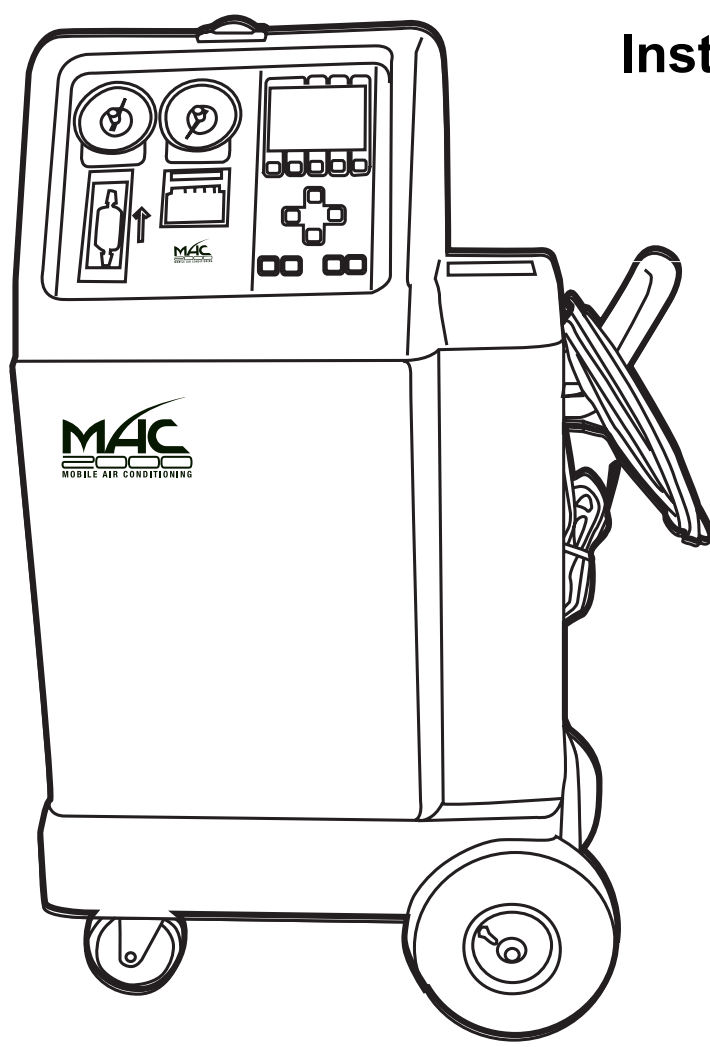

WARRANTY

Bacharach, Inc. warrants to Buyer that at the time of delivery this Product will be free from defects in material and manufacture and will conform substantially to Bacharach Inc.'s applicable specifications. Bacharach's liability and Buyer's remedy under this warranty are limited to the repair or replacement, at Bacharach's option, of this Product or parts thereof returned to Seller at the factory of manufacture and shown to Bacharach Inc.'s reasonable satisfaction to have been defective; provided that written notice of the defect shall have been given by Buyer to Bacharach Inc. within one (1) year after the date of delivery of this Product by Bacharach, Inc.

Bacharach, Inc. warrants to Buyer that it will convey good title to this Product. Bacharach's liability and Buyer's remedy under this warranty of title are limited to the removal of any title defects or, at the election of Bacharach, to the replacement of this Product or parts thereof that are defective in title.

THE FOREGOING WARRANTIES ARE EXCLUSIVE AND ARE GIVEN AND ACCEPTED IN LIEU OF (I) ANY AND ALL OTHER WARRANTIES, EXPRESS OR IMPLIED, INCLUDING WITHOUT LIMITATION THE IMPLIED WARRANTIES OF MERCHANTABILITY AND FITNESS FOR A PARTICULAR PURPOSE; AND (II) ANY OBLIGATION, LIABILITY, RIGHT, CLAIM OR REMEDY IN CONTRACT OR TORT, WHETHER OR NOT ARISING FROM BACHARACH'S NEGLIGENCE, ACTUAL OR IMPLIED. The remedies of the Buyer shall be limited to those provided herein to the exclusion of any and all other remedies including, without limitation incidental or consequential damages. No agreement varying or extending the foregoing warranties, remedies or this limitation will be binding upon Bacharach, Inc. unless in writing, signed by a duly authorized officer of Bacharach.

Note: *The Filter Drier and Refrigerant Identifier Filter are considered consumable items, and are therefore not covered under the terms of this warranty.*

**Register Your Warranty by Visiting
www.bacharach-inc.com**

Notice:

Product improvements and enhancements are continuous; therefore the specifications and information contained in this document may change without notice.

Bacharach, Inc. shall not be liable for errors contained herein or for incidental or consequential damages in connection with the furnishing, performance, or use of this material.

No part of this document may be photocopied, reproduced, or translated to another language without the prior written consent of Bacharach, Inc.

Copyright © 2002, Bacharach, Inc., all rights reserved.

BACHARACH® is a registered trademark of Bacharach, Inc. All other trademarks, trade names, service marks and logos referenced herein belong to their respective owners.

Table of Contents

| | | |
|----------|---|-----------|
| 1 | Introduction | 1 |
| 1.1 | Glossary of Terms..... | 2 |
| 1.2 | General Operating Guidelines..... | 2 |
| 1.3 | Component Location and Description | 3 |
| 1.4 | Using the Function Keys..... | 7 |
| 1.5 | Using the Up/Down, Increase, Decrease, and Back/Forward Arrow Keys..... | 7 |
| 2 | Initial Set-Up..... | 9 |
| 2.1 | Initial Set-Up Instructions | 9 |
| 2.2 | Checking Vehicles for Possible Contaminated Systems..... | 11 |
| 2.3 | External Source Tank Testing..... | 11 |
| 3 | Operation | 13 |
| 3.1 | MAC2000 Operational Overview..... | 13 |
| 3.2 | Diagnosing A/C System Operation Using the Snap-Shot Mode | 15 |
| 3.3 | Recovery Mode..... | 18 |
| 3.4 | Vacuum Mode (Evacuation)..... | 19 |
| 3.5 | Charge Mode..... | 20 |
| 3.6 | System Flush Mode (Oil Flush)..... | 22 |
| 3.7 | Refrigerant Management System | 24 |
| 3.8 | Internal Tank Manual Refill | 25 |
| 3.9 | System Set Up | 26 |
| 3.10 | Identify Refrigerant | 26 |
| 3.11 | Check Internal Tank for Air | 27 |
| 4 | Maintenance..... | 29 |
| 4.1 | Changing the Filter Drier | 29 |
| 4.2 | Replacing the External Source Tank | 30 |
| 4.3 | Replacing the Printer Paper | 31 |
| 4.4 | Replacing the Refrigerant Identifier Filter..... | 32 |
| 5 | Parts and Service | 33 |
| 5.1 | Parts..... | 33 |
| 5.2 | Service Centers..... | 34 |

SERIES: MAC2000
KENT MOORE: J-055000



Refrigerant: 134a

Air Conditioning and Refrigerant Service Solution



PRESSURIZED TANK CONTAINS LIQUID REFRIGERANT. OVERFILLING OF THE TANK MAY CAUSE VIOLENT EXPLOSION AND POSSIBLE INJURY OR DEATH. Safety devices require the use of only authorized refillable tanks. Refer to the instruction manual for tank specifications and ordering information. Do not recover refrigerants in a non-refillable storage container! Regulations require refrigerant to be transported only in specifically authorized containers.

ALL HOSES MAY CONTAIN LIQUID REFRIGERANT UNDER PRESSURE. Contact with refrigerant may cause injury. Wear proper protective equipment, including safety goggles. Disconnect hoses with extreme caution.

HIGH VOLTAGE ELECTRICITY INSIDE PANELS. RISK OF ELECTRICAL SHOCK. Disconnect power before service unit. Refer to the instruction manual.

TO REDUCE RISK OF FIRE, avoid the use of an extension cord. The extension cord may overheat. If you must use an extension cord, the cord must be 14 AWG minimum and as short as possible. Do not use this equipment in the vicinity of spilled or open containers of gasoline or other flammable substances.

Use this equipment in locations with mechanical ventilation that provides at least four air changes per hour or locate the equipment at least 18 inches above the floor.

Make certain that all safety devices are functioning properly before operating the unit. Before operating, read and follow the instructions and warnings in the manual.

CAUTION: SHOULD BE OPERATED BY QUALIFIED PERSONNEL. Technician must be familiar with air conditioning and refrigeration systems, refrigerants and the dangers of pressurized components.

Use with the R-134a refrigerant only. This equipment is not designed for any other purpose other than recovering, recycling and charging refrigerants. Do not mix refrigerant types.

OPERATING NOTES

Change the filter-drier when the display shows Change Filter message. Follow the instructions for the changeover. At temperatures exceeding 120 °F / °C, wait 10 minutes between recovery jobs.

R-134a WARNINGS!

Use the MAC2000 unit only with R-134a refrigerants. Cross-contamination with other refrigerant types will cause severe damage to the A/C systems and to service tools and equipment. Do not mix refrigerant types through a system or in the same container.

Avoid breathing A/C refrigerant and lubricant vapor mist. Exposure may irritate eyes, nose and throat. To remove R-134a from the system, use service equipment certified to meet the requirements of SAE-J2210 (R-134a recycling equipment). If accidental system discharge occurs, ventilate work area before resuming service.

HFC-134a service equipment or vehicle A/C systems should not be pressured tested or leak tested with compressed air. Some mixtures of air/HFC-134a have been shown to be combustible at elevated pressures. These mixtures are potentially dangerous and may result in fire or explosion causing injury or property damage.

Additional health and safety information may be obtained from refrigerant and lubricant manufacturers.

1 Introduction

Important! *These instructions are for qualified personnel, trained and experienced in the handling of refrigerants. Federal and state laws may require the licensing of refrigerant handling personnel. Failure to follow proper operating procedures may cause personal injury and equipment damage*

The Bacharach Test System's Mobile Air Conditioning MAC2000 is the most advanced refrigerant management system on the market today. It is a complete automotive A/C service tool that will identify, recover, recycle, flush and troubleshoot automotive R-134a A/C systems in a fully automatic manner.

A large liquid crystal diode (LCD) display screen prompts the technician for input and displays system status. An internal 30 pound recovery tank and electronic scale ensure convenient refrigerant storage and accurate refrigerant management.

Upon power up, the unit performs a self-test and, if necessary, a self-evacuation routine. The technician may then select the specific function required for the job. During operation, the MAC2000 checks for error conditions and alerts the technician if any exist.

The entire service procedure can be done with one hook-up to the vehicle. A built-in refrigerant identifier checks for contaminated refrigerant prior to recovery. Pressures are shown on the high and low side gauges, and other operating information is shown on the screen.

Refrigerant is recovered into and charged out of an internal storage tank. The MAC2000 unit automatically refills this tank with refrigerant from an external source tank as needed in order to maintain a constant 12–15 lbs (5.45–6.82kg) of refrigerant available for charging. One quick connection is all that's needed to replace the source tank when it is empty.

Other time saving features include automatic air purge, single pass recycling, and automatic oil drain. The unit also automatically clears refrigerant from its high- and low-side hoses after every job. A red light on top of the unit flashes whenever a process is complete or when the unit needs attention from the technician.

The MAC2000 is ETL listed to UL standards and meets SAE specifications for recycled refrigerant.

1.1 Glossary of Terms

| | |
|------------------------|--|
| A/C | Air conditioner or air conditioning |
| A/C System Unit | The vehicle's air conditioning system |
| Screen | The MAC2000 itself |
| Contaminated | LCD Display |
| | Refrigerant that has been mixed with some other type of refrigerant. |

1.2 General Operating Guidelines

- The MAC2000 monitors the AC line voltage and disables itself if the voltage drops below 100 VAC or rises above 135 VAC. An error message will be displayed on screen when the line voltage is out of tolerance. The unit must be turned OFF and then back ON to reset the voltage monitoring circuitry. Extension cords must be a minimum of 14 AWG and kept as short as possible.

Common causes for electrical problems include:

- Long extension cords
 - Faulty, overloaded electrical circuits
 - Drop lights
 - Improper ground or improper polarity
- The screen shows options and gives instructions for most service and maintenance tasks. Read the on-screen prompts and follow their instructions.
 - The MAC2000 prompts a technician to check the system oil drain bottle on the side of the unit for recovered oil. Any system oil that is lost is automatically drained during recovery. A technician must measure and record the lost amount of oil in order to know how much new oil to add during charging. Refer to the A/C system manufacturer's service manuals for oil specifications. Dispose of used oil properly.
 - In general, it is best to leave the MAC2000 turned ON throughout the workday. This allows the unit time to purge itself of air and refill the internal storage tank. Turn the unit OFF at the end of the day.

1.3 Component Location and Description

MAC2000 Control Panel

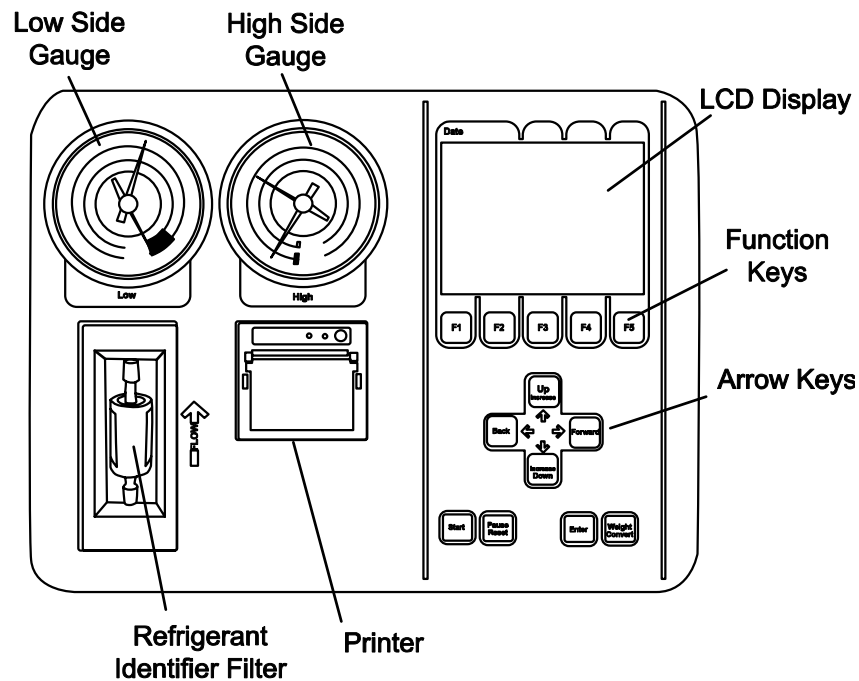

High Side Gauge – Shows the pressure in the high side of the vehicle’s A/C system.

Low Side Gauge – Shows the pressure in the low side of the vehicle’s A/C system.

LCD Display (Screen) – Displays all operational, error, and maintenance messages.

Refrigerant Identifier Filter – Protects the refrigerant identifier sensor from contaminants.

Printer – Provides a printed record of the functions performed by the MAC2000. The printer can print the record of the MAC2000’s last operation as well as other refrigerant management data and operational statistics.

Start Key – Press to start a function.

Pause/Reset Key – Press to either pause, reset, or abort a function and return the display to the Main menu.

Enter Key – Press to accept a value as displayed on the screen.

Weight Convert Key – Press to change the charge amount between pounds, pound & ounces, and kilograms. Pushing this key allows a technician to scroll through the different weight units.

Arrow Keys – Use these keys to select variables and adjust values such as charge weight and vacuum time. The **Increase** and **Decrease** keys are used to adjust numerical values, while the **Back**, **Forward**, **Left** and **Right** keys are used to move between values displayed on the screen.

F1 – F5 Function Keys – Use these keys to select various modes and functions on the MAC2000. A key’s current function is described directly above it on the screen.

MAC2000 Front View

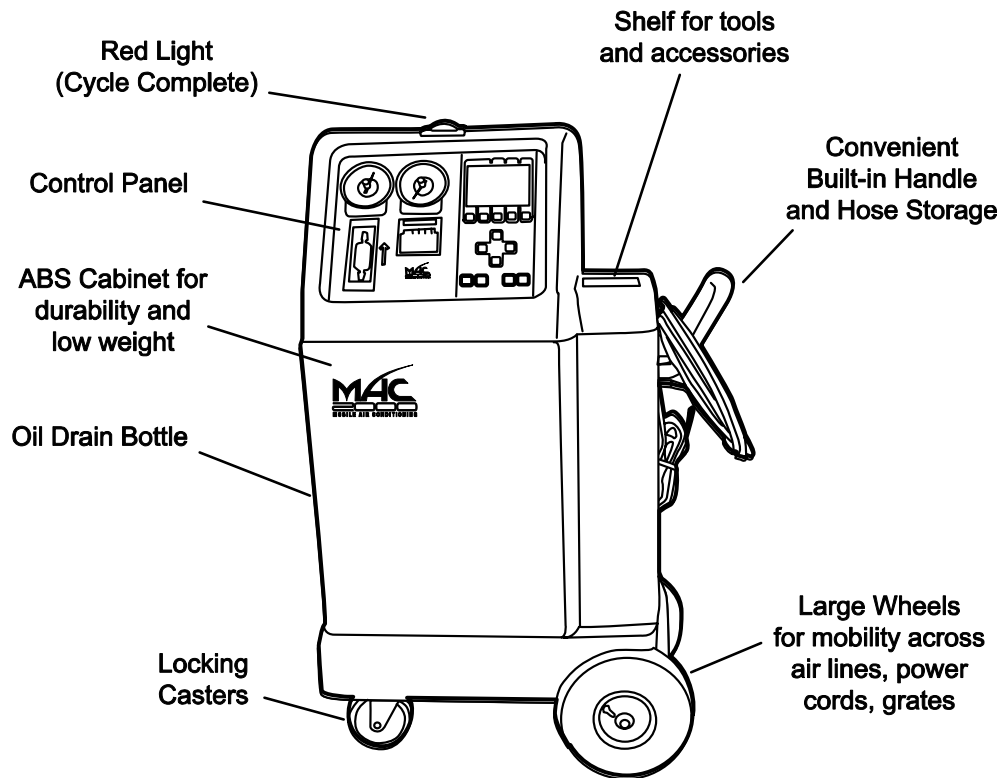

MAC2000 Right-Side View

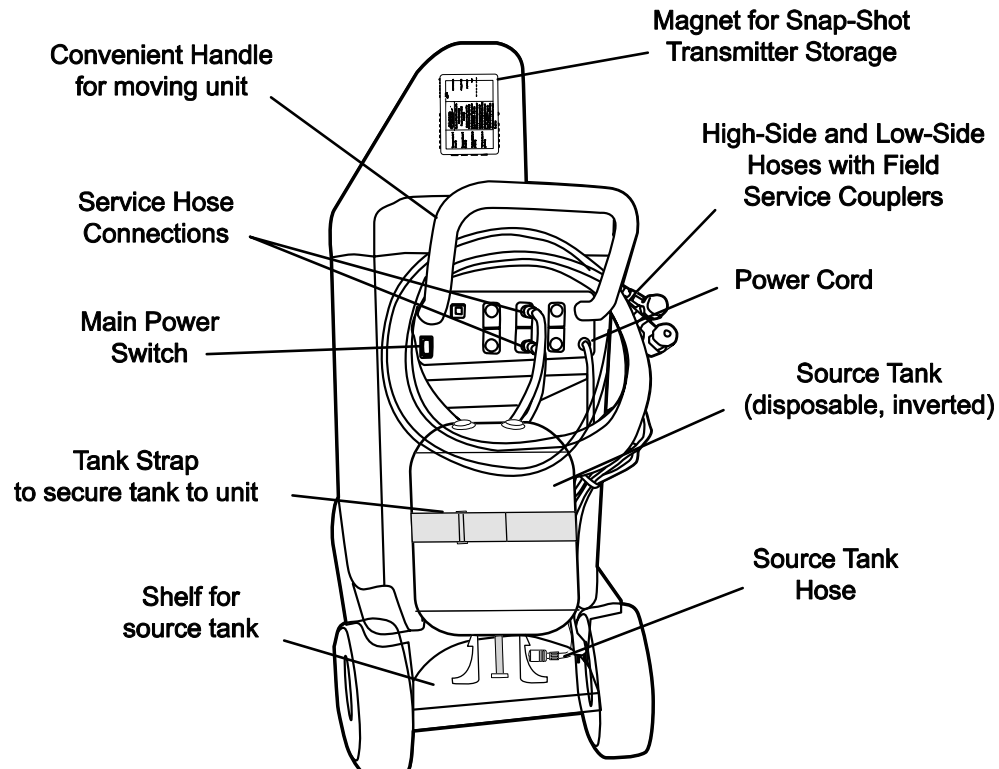

MAC2000 Left-Side View

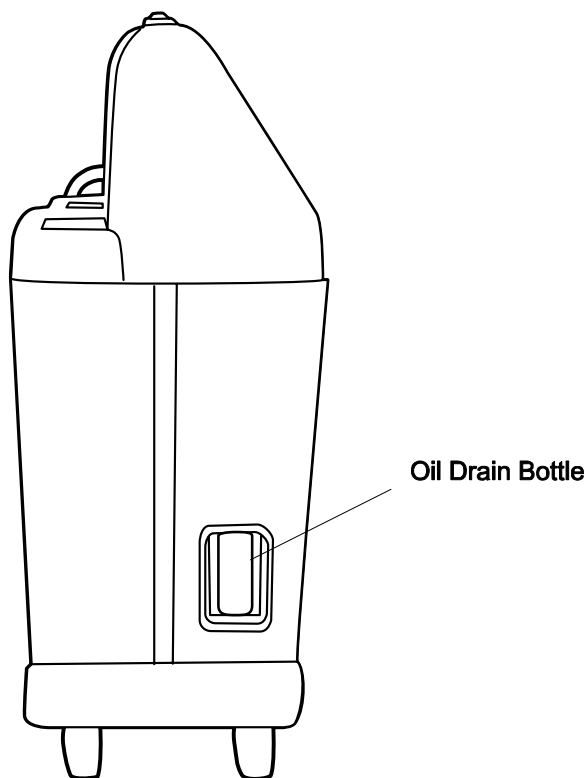

MAC2000 Back View

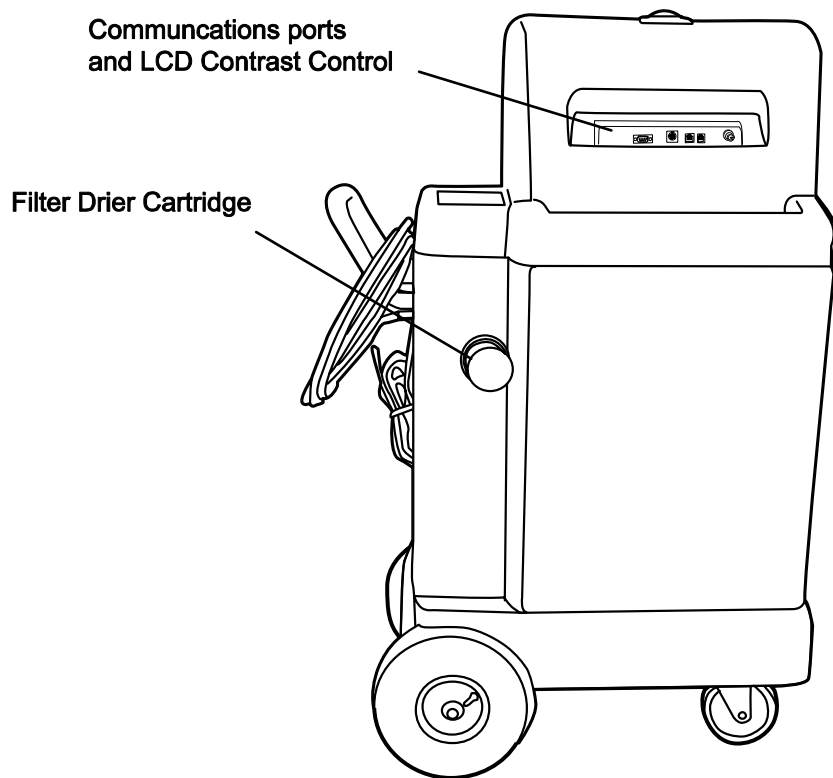

Closeup of MAC2000 Handle Panel

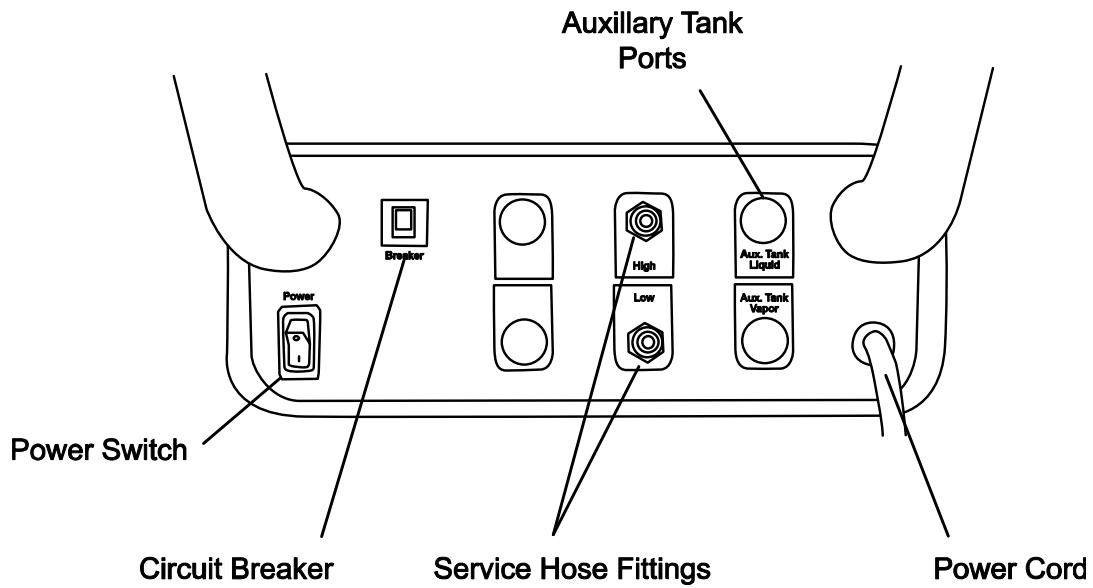

Note: The auxiliary tank ports are not used as this time.

Temperature and Velocity Data Ports

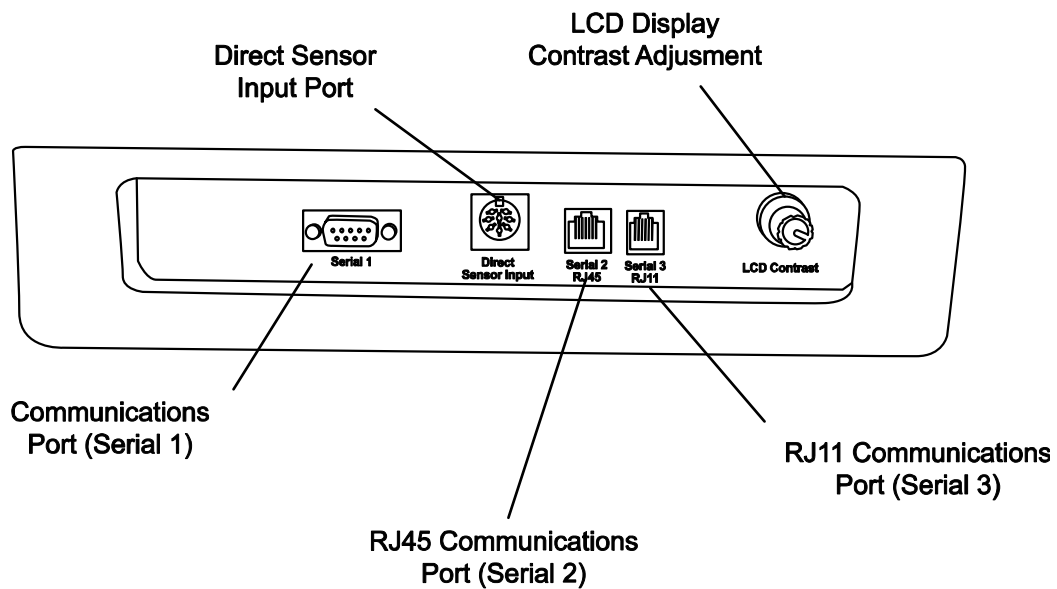

Note: The communications ports are used for software updates and future options, and are not used during normal operation.

1.4 Using the Function Keys

The operation of each function key (F1–F5) depends on the service operation and unit status. The display shows five labels along the bottom of the screen pointing to the function keys below. Each label shows the action the key will activate. To make a selection, press the function key immediately below the arrow.

The **Next menu** function key takes the technician to the next set of menu items. There will always be a menu item to take the technician back to the main menu.

1.5 Using the Up/Down, Increase, Decrease, and Back/Forward Arrow Keys

Pressing the **Up/Down** and **Back/Forward** keys moves the cursor on the screen in that direction. In addition, when entering numeric data, pressing the **Increase** key will increase the number, while pressing the **Decrease** key will decrease the number.

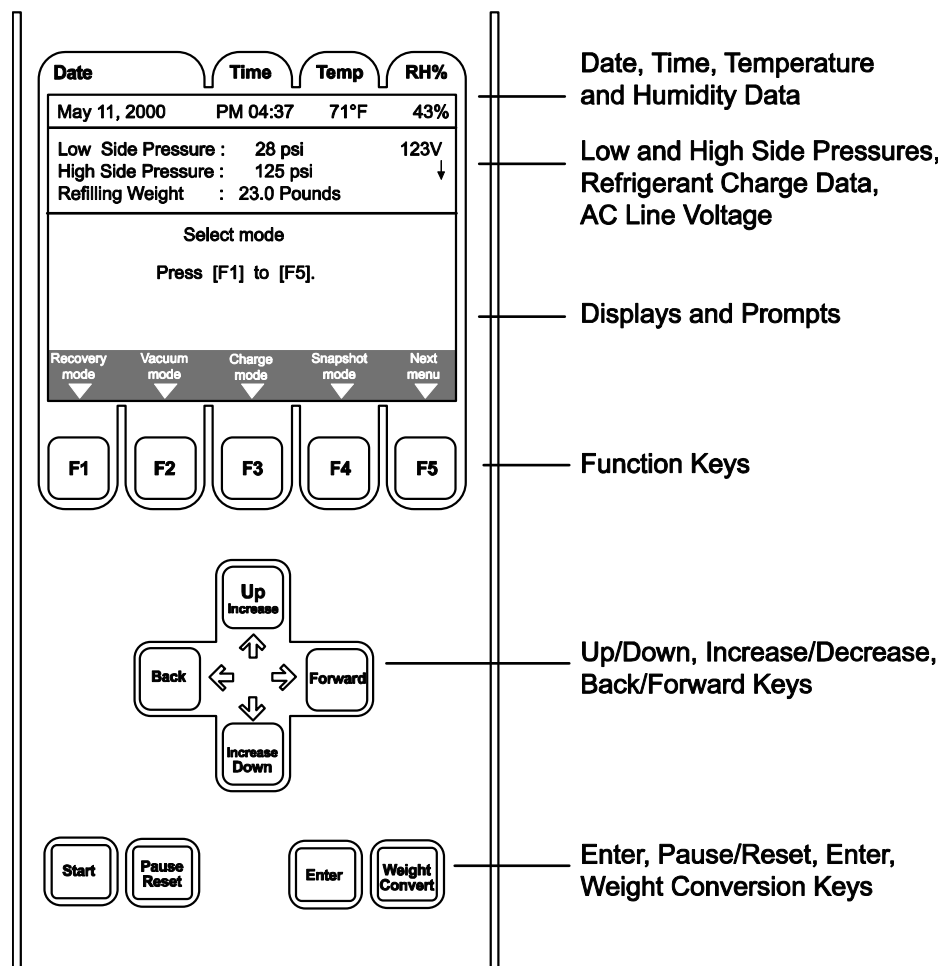

Notes:

2 Initial Set-Up

2.1 Initial Set-Up Instructions



WARNING



It is extremely important to follow these instructions! Improper setup will result in potential inaccuracies when operating the unit.

1. Un-box the MAC2000.
2. Open the accessory box that contains the rear and side tray mats, the high- and low-side service hoses, the snap-shot transmitter, and one spare printer paper roll.
3. Drop the mats into the side and rear storage trays.
4. Attach the blue low-side service hose to the service-hose fitting with the blue label, and attach the red high-side service hose to the red service fitting.
5. Attach the snap-shot transmitter to its magnetic storage plate.
6. Install an external source tank of R-134a refrigerant on the lower shelf of the unit, below the handle. The external source tank should be *inverted* so liquid refrigerant is supplied to the internal tank. The MAC2000 can handle 30 lb (14kg) or 50 lb (23kg) commercial tanks. Secure the tank to the unit by placing the strap around the tank and tightening it. **WARNING: Failure to secure the source tank properly could result in injury!**

Side and Rear Storage Trays

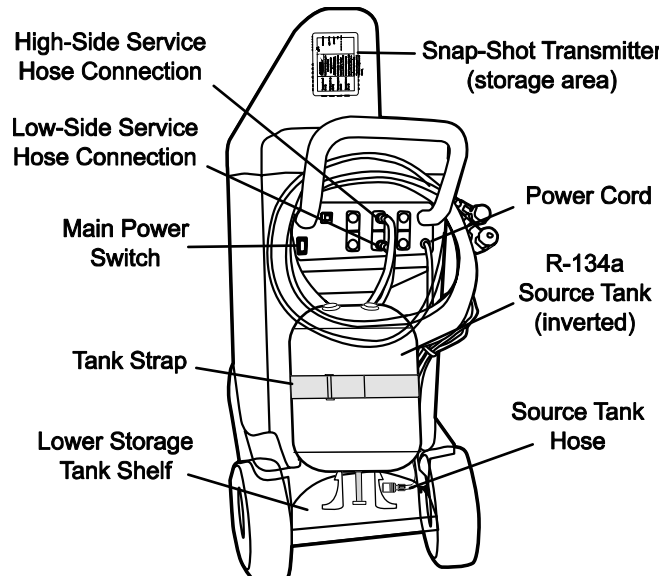
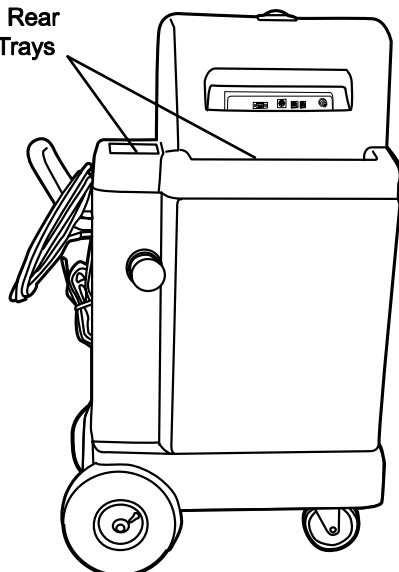

7. Attach the yellow refill hose coming from behind the tank to the source tank fitting. Open the source tank valve. To avoid the possible of lost refrigerant, the external source tank should be checked for leakage around the tank valve. If leakage is found, close the valve and keep it closed at all times *except* during a manual tank refill operation as described in Section 3.8. Bacharach Test Systems *does not* reimburse for lost refrigerant.
8. Attach the unit's power cord to 115VAC 50/60 Hz, 15 Amp grounded outlet. Avoid using long extension cords.
9. Set the main **Power** switch (located under the handle) to ON.
10. There is a brief initialization period of several seconds. The technician will be prompted to set-up the following parameters. (This initial set-up procedure occurs only once when a new unit is turned on. Subsequent changes can be made using the System Set-Up mode per Section 3.9 at any time.)
 - a) Set Date & Time: Press the **Enter** key to change the date. Use the **Left/Right** and **Up/Down** keys to make adjustments. Press the **Enter** key again to save the changes.
 - b) Select Language: Select the preferred Language.
 - c) Select Units: English or Metric (English is the Default).
 - d) Calibrate the Pressure Transducers: Remove high- and low-side hoses from side of unit; then follow on-screen prompts to calibrate the pressure sensors.
 - e) Set Elevation: Enter the unit's elevation above sea level for your location \pm 500 feet.
11. The MAC2000 now automatically evacuates all air from the internal circuit and tank, and pre-charges the tank with 12 lbs of R-134a. This process takes approximately 15 – 20 minutes.

**WARNING**

Always wear eye protection when working with refrigerants. Refrigerants can cause injury. Read and follow all warnings at the beginning of this manual before operating this unit.

CAUTION! R-134a systems have special fittings (per SAE specifications) to avoid cross contamination with R12 systems. Do not attempt to adapt your unit for another refrigerant type system, or failure will result!

12. The MAC2000 is now set-up and ready for operation.

2.2 Checking Vehicles for Possible Contaminated Systems

Before every recovery, the MAC2000 automatically samples the refrigerant in the vehicle's A/C system. If the system fails the purity level required, the unit tests a second time. In the event the system fails a second time, the unit prompts that the hoses be disconnected from the vehicle. Follow the on-screen prompts in order to clean out the MAC2000.

Note: *The MAC2000 must be disconnected from the vehicle before starting the cleaning process. It is illegal to knowingly vent or allow refrigerant to vent to the atmosphere. This illegal venting will occur if the unit is left attached to the vehicle.*

Please refer to your shop's policy for dealing with contaminated refrigerant.

2.3 External Source Tank Testing

The MAC2000 features an exclusive source tank refrigerant identification process that checks the source refrigerant before it is added to the unit's internal tank. This testing is automatic and does not require any action by the technician. This feature prevents contaminated refrigerant from entering the MAC2000, thus rendering it inoperable.

Notes:

3 Operation

3.1 MAC2000 Operational Overview

The MAC2000 is an EPA-approved, ETL-listed, single-pass recycling system. During the recovery operation, refrigerant is removed from the vehicle and passed through an oil separator and filter drier before entering the storage tank.

The MAC2000's refrigerant weighing system is extremely accurate. It has sophisticated error correction capability that minimizes incorrect readings caused by bumps or vibration. Even with this protection, however, the MAC2000 should be placed on level ground and out of the way of foot traffic. Do not touch or move the unit while it is operating!

To ensure that the displayed reading of recovered refrigerant is accurate, the unit will perform a low side clearing routine, if necessary, when the power is turned on. If refrigerant is sensed in the accumulator, the screen will display "**Clearing System**". This indicates refrigerant in the accumulator is being transferred to the storage tank.

At any time during system operation, pressing the **Weight Convert** key can change the weight units. The available units are pounds only, pounds & ounces, or kilograms.

Power Up – When power is applied, the unit performs a self-diagnostics. When these tests are complete, the display shows "**Select mode.**"

Main Data Display – (See illustration of Main Data Display in Section 1.5 on Page 7.) Shows the date, time, ambient temperature, RH%, AC line voltage, low- and high-side pressures, and the amount of refrigerant available for charging. Use the function keys (F1 – F5) to select the desired mode as described in the following paragraphs.

Main Menu

| | | | | |
|---------------|-------------|-------------|---------------|-----------|
| Recovery mode | Vacuum mode | Charge mode | Snapshot mode | Next menu |
|---------------|-------------|-------------|---------------|-----------|

- **Recovery mode** – Recovers and recycles refrigerant from a vehicle's A/C system. This mode is most often used prior to opening an A/C system to atmosphere to replace a system component.
- **Vacuum mode** – Removes residual air and moisture from a system previously opened to the atmosphere. This mode also allows a technician to verify that the A/C system will hold a vacuum for a certain length of time.
- **Charge mode** – Select this mode to add refrigerant to an A/C system; also most commonly used to “top off” the system.
- **Snap-Shot mode** – Monitors and records important operating information including the high- and low-side pressures, ambient temperatures, A/C vent temperatures, ambient humidity, and (optionally) vent air flow velocities. This information is used to diagnose and measure A/C performance before and after service.
- **Next menu** – Displays Menu 2.

Menu 2

| | | | | |
|-----------|--------------|-------------|---------------|-----------|
| Main menu | System flush | Tank refill | System set-up | Next menu |
|-----------|--------------|-------------|---------------|-----------|



- **Main menu** – Returns display to the Main menu.
- **System flush** – Removes all oil and refrigerant from an A/C system. This mode is often used prior to retrofitting a system to R-134a.
- **Tank refill** – Overrides the automatic tank refill function of the MAC2000 and transfers refrigerant from the external source tank to the internal storage tank.
- **System set-up** – Sets up certain operating parameters in order for the MAC2000 to operate correctly. The set-up information must be entered prior to operating the MAC2000.
- **Next menu** – Displays Menu 3.

Menu 3

| | | | | |
|-----------|---------------|----------------|------------|---------------|
| Main menu | Identify mode | Check tank air | Refri data | Filter change |
|-----------|---------------|----------------|------------|---------------|

- **Main menu** – Returns display to the Main menu.
- **Identify mode** – Identifies refrigerant in a vehicle's A/C system without having to recover the refrigerant. After the unit is finished identifying the refrigerant the display returns to the Main menu.
- **Check tank air** – This option allows a technician to manually check the internal source tank for air and other non-condensables, and then purges the tank if too much air is present.
- **Refri data** – Accesses the unit's historical refrigerant data.
- **Filter change** – Removes refrigerant from the filter dryer prior to its replacement.

3.2 Diagnosing A/C System Operation Using the Snap-Shot Mode

| | | |
|--|----------------|---|
|  | WARNING |  |
| <p>Always wear eye protection and protective clothing when working with refrigerants. Observe all warnings at the beginning of this manual. Be sure the vehicle is in PARK before turning on the engine. Provide adequate ventilation or pipe exhaust to outside. Vehicle exhaust fumes can cause injury or death.</p> | | |

To assist in system diagnostics, the MAC2000's Snap-Shot mode allows a technician to monitor and record the following key operating information from the vehicle being serviced. This data can be collected before and after servicing to show any changes in performance of a vehicle's A/C system.

- Date and Time
- Ambient Temperature & Humidity
- Low Side System Pressure, minimum and maximum values
- High Side System Pressure, minimum and maximum values
- Front Duct Temperature, minimum value
- Rear Duct Temperature, minimum value
- Refrigerant Identifier Results

Data is collected from inside the vehicle's passenger compartment by means of the snap-shot transmitter (shown below). This transmitter is powered from the vehicle's cigarette-lighter, and wirelessly transmits temperature (and optional air flow) data to the MAC2000.

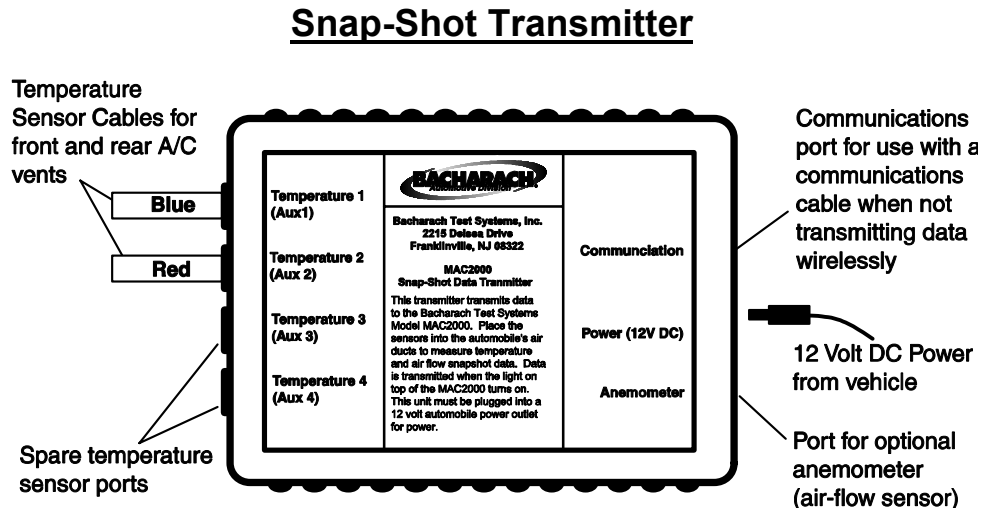

Red Temperature Sensor – This sensor should be used on the front A/C vent in the vehicle. The temperature is displayed as “RED TEMPERATURE” on the Snap-Shot mode screen.

Blue Temperature Sensor – This sensor should be used on the rear A/C vent. The temperature is displayed as “BLUE TEMPERATURE” on the Snap-Shot mode screen.

Anemometer (optional) – The optional Anemometer measures airflow. This sensor can be purchased separately.

Communications Port – Used to connect the transmitter directly to the MAC2000 via a cable (instead of transmitting data wirelessly). This port is not normally used, and requires a cable (not included).

Enter the Snap-Shot mode as follows:

1. If not already done, plug the MAC2000 into a properly grounded AC outlet; set the **Power** switch to ON; then wait until the unit completes its self diagnostics. The screen will display “**Select mode**” when ready.
2. Press the **Snapshot mode** function key to select the Snap-Shot mode.

3. Follow the instructions on the screen. A technician will be instructed to connect the high- and low-side service hoses to their respective service ports on the vehicle's A/C system and open the A/C system's service-port valves. Connect the red and blue temperature sensors, start the vehicle, then turn the vehicle's A/C system to its maximum cool or re-circulating setting.
4. Press the unit's **Start** key.
5. After identifying the refrigerant in the vehicle, the MAC2000 displays and updates the minimum and maximum values as shown on the display. The snap-shot display can now be used to monitor the performance of the vehicle's A/C system.
6. While in the snap-shot mode, the following operations can be performed:

| Main menu | Capture (Print) | Reset | Recover |
|-----------|-----------------|-------|---------|
|-----------|-----------------|-------|---------|

- **Main menu** – Returns display to the Main menu.
- **Capture (Print)** – Prints the following data:

```

---Snap-shot report---
Date      :May 18, 2001
Time      :PM 02:14
Low PSI   :(min)  17   (max)  18
High PSI  :(min)  17   (max)  18
Duct Air Flow. : (max)  0 ft/m
Blue vent. Temp.: (min)  8 F
Red vent Temp. : (min)  73 F
Ambient Temp.  :          73 F
Ambient Humidity:        49 RH%

---Identifier result ---
RECOVERABLE
R134a:  99.9%      R12 :  0.0%
R-22:   0.0%      HC  :  0.0%
AIR:    1.5%

---Snap-shot encrypted code---
001 Q54 L6G 028 M94 H29

```

- **Reset Values** – Resets and begins tracking new min. and max. values.
- **Recover** – Starts a recovery operation.

3.3 Recovery Mode

The recovery mode removes all refrigerant from the vehicle's A/C system and stores it in the unit's internal storage tank. Before recovery begins, however, there must be pressure in the hoses. This prevents inadvertent recovery of air or other contaminants from a leaking system. The MAC2000 will automatically sense the presence of refrigerant and confirm that it is not contaminated before starting the recovery process.

Begin the refrigerant recovery process as follows:

1. If not already done, plug the MAC2000 into a properly grounded AC outlet; set the **Power** switch to ON; then wait until the unit completes its self diagnostics. The screen will display "**Select mode**" when ready.
2. Press the **Recovery mode** function key and observe the following message: "**Hook-up the service hoses to vehicle.**"
3. At this time hook up the service hoses, open the A/C system's service-port valves, and then press the unit's **Start** key. The refrigerant identifier will warm up, zero itself, and then display the message "**Analyzing sample, please wait . . .**"

If the refrigerant is contaminated (meaning that it has somehow been mixed with some other kind of refrigerant), the results will be displayed along with the word "**contaminated.**" Note that the unit will not allow the recovery operation to proceed when refrigerant is contaminated.

If the refrigerant is found to meet specifications, the unit will automatically proceed to recover the refrigerant. During the recovery operation, refrigerant is removed from both the high and low side of the vehicle's A/C system. The screen will display "**Recovering refrigerant**" along with showing the amount of refrigerant being recovered.

4. When the A/C system has been recovered to a minimum vacuum of 9 inHg, the recovery process automatically stops. The following events then occur:
 - The unit's red light flashes and the beeper sounds, signaling the technician that recovery is complete.
 - The screen reads "**Recovery complete**" and shows the weight of the recovered refrigerant.
 - System oil is automatically drained into the oil drain bottle (see MAC2000 Left-Side View, Page 5).

Note: *The MAC2000 will automatically restart the recovery process if the unit senses a rise in the A/C system's pressure.*

5. After recovering the refrigerant from the A/C system, close the service-port valves, and then remove the hoses from the vehicle.

Observe that the service hoses should remain under vacuum. This ensures that no contaminants are introduced into the A/C system during a recharge process.

6. The technician can now begin repairs on the A/C system.

3.4 Vacuum Mode (Evacuation)

The Vacuum mode is used to remove residual air and moisture from the vehicle's A/C system by pulling the system into a deep vacuum. This mode is most often used after completing a repair that required opening the A/C system to the atmosphere. Moisture and/or air in an A/C system can cause erratic operation and must be removed before recharging the system with refrigerant.

Evacuate a vehicle's A/C system as follows:

1. If not already done, plug the MAC2000 into a properly grounded AC outlet; set the **Power** switch to ON; then wait until the unit completes its self diagnostics. The screen will display "**Select mode**" when ready.
2. Connect the high- and low-side service hoses to their respective service ports on the vehicle's A/C system; then open the A/C system's service-port valves.
3. Press the **Vacuum mode** function key and observe that the screen reads "**Set VACUUM TIME now.**" The minimum evacuation time is 3 minutes. To change this time, press and hold the **Increase** key until the desired time is shown.
4. Press the **Start** key to begin the evacuation process.

Note: *Before evacuation begins, the MAC2000 checks if pressure is present in the vehicle. If pressure is sensed, the unit will display the message: "**Error: You have pressure in the hoses. You must first recover this refrigerant before proceeding.**" If this error message appears, first abort the evacuation process by pressing the **Reset** key, recover the system per Section 3.3, then restart the evacuation process by pressing the **Vacuum mode** function key.*

5. The evacuation process continues for the amount of time set in Step 3. If a vacuum level of at least 27 inHg is not achieved within the prescribed time, the evacuation process automatically continues for a maximum of 7 minutes, or until 27 inHg is

achieved. When the A/C system reaches the proper vacuum, the unit's red light and beeper signal evacuation is complete, and the screen reads "**Vacuum complete.**" If the proper vacuum is *not* achieved after 7 minutes of evacuation, the process stops, and the technician is prompted to check for a leak.

Note: *Depending on the altitude, the A/C system may not be able to achieve 27 inHg. It is important that the altitude setting in the Set-Up menu is correct for your location. The MAC2000 uses this information to calculate and provide an equivalent set point for your altitude. (For instance, at 6000 feet the equivalent set point for your altitude pulls to 22 inHg before completing evacuation).*

6. Press the **Reset** key to return to the Main menu.
7. The technician can now proceed to charge the system.

3.5 Charge Mode

The Charge mode is designed to add a precise amount of refrigerant to the vehicle's A/C system. This mode can be used to either "top off" a system, or do a complete recharge after the system has been evacuated or flushed. The unit has a built-in default charge amount of 2 pounds (0.91 kg). Other charge amounts can be entered in increments of either 0.06 pounds, 1 ounce, or 0.02 kg.

1. If not already done, plug the MAC2000 into a properly grounded AC outlet; set the **Power** switch to ON; then wait until the unit completes its self diagnostics. The screen will display "**Select mode**" when ready.
2. Press the **Charge mode** function key and observe that the message "**Hook-up the service hoses to vehicle**" should appear. If not already done, connect the high- and low-side service hoses to their respective service ports on the vehicle's A/C system, and then open the system's service-port valves.

Note that at the start of this step, before the service hoses are connected, the MAC2000 first checks if the service hoses are under a vacuum. This prevents air and other contaminants from being introduced into the A/C system. If the message "**The vehicle is not properly evacuated**" appears, perform one of the following:

- If the refrigerant in the A/C system has just been recovered, evacuate both the system and the service hoses per Section 3.4.
- If the A/C system needs to be "topped off," first ensure that the service hoses are disconnected from the vehicle; then either recover the hoses per Section 3.3 if they contain refrigerant, or evacuate the hoses per Section 3.4 if they contain air.

3. After entering the Charge mode, the following options are available:
 - Press the **Enter** key to accept the 2.00 pound Default.
 - Press the **Weight Convert** key to change the “**Set charge weight**” units.
 - Use the **Increase** or **Decrease** keys to set the desired charge amount. Select the next higher value if the exact charge amount cannot be entered. Press **Enter** to accept the charge amount shown on the screen.

Note: *The MAC2000 charges in one-ounce increments, regardless of which unit of measure is selected. This means that sometimes the exact charge amount cannot be entered. For example, the A/C system may require a 1.03 kg charge. The MAC2000 will only allow a setting of 1.02 kg or 1.04 kg. In this instance, always select the next higher value. This difference is only 0.3 of an ounce, which will not affect the vehicle’s A/C performance.*

4. By default the MAC2000 charges liquid refrigerant directly into the high side of the A/C system. A technician, however, may choose to charge into both the high and low side by pressing the **Low side ON-OFF** function key. Pressing this key toggles the low-side option on and off. **Important!** *Charging liquid directly into the low side of the compressor could slug the compressor and cause permanent damage. Check with the compressor manufacture before proceeding.*
5. The screen should now show the amount of refrigerant set for charging. Press the **Start** key to begin the charging process.

During the charging process, liquid refrigerant is drawn from the unit’s internal storage tank and charged through the high side (and optionally the low side) of the vehicle’s A/C system. The screen will show the progress of this charging process.

Important! *Do not disturb or bump the MAC2000 during charging as any jarring movement can affect the charge accuracy.*

Note: *If an insufficient pressure differential exists between the tank and the system, charging suspends and the MCR2000 goes into a power-charge mode to increase tank pressure to complete the charge. This normally occurs only when the unit has been in a very cold environment prior to use.*

6. When charging is complete, the red light and beeper signal that the process is complete. The MAC2000 automatically goes into the Snap-Shot mode, thus allowing a technician to obtain an after-service snap-shot of important operating parameters of the A/C system. Refer to Section 3.2 for details.

7. If more refrigerant needs to be added, press the **Additional Charge** function key. Otherwise, press the **Done** function key to exit the Snap-Shot mode.
8. Close the service-port valves; remove the service hoses from the vehicle; then press the **Start** key to recover the hoses.

Important! *If the hoses are not removed from the vehicle before the **Start** key is pressed, the refrigerant in the vehicle will be recovered!*

9. If any oil was removed during the recovery or evacuation process, make sure that the proper amount of oil is added back into the vehicle's A/C high side port in accordance with the vehicle manufacturer's recommendations. Add an amount of new oil equal to the amount collected in the oil drain bottle (see MAC2000 Left-Side View, Page 5).

3.6 System Flush Mode (Oil Flush)

The System Flush mode is designed to be used on General Motors vehicles using their Oil Flush Adapter and Filter accessory. This accessory is attached inline with the vehicle's compressor and is used to flush the A/C system with refrigerant. In this mode, refrigerant is circulated through both the A/C system and the MAC2000 where an oil separator removes the oil and returns oil-free refrigerant back into the A/C system for further flushing. At the end of the cycle, the refrigerant is completely removed from the A/C system and stored in the unit's internal storage tank. The flushing process can take up to 30–45 minutes to complete. Because of the variety of A/C system configurations currently in service, the flush may bypass certain sections of the A/C system. To ensure the complete system is flushed, the technician may need to pinch off certain hoses to force the refrigerant flush throughout the system.

1. Before beginning the flushing process, recover all refrigerant from the vehicle's A/C system per Section 3.3 *Recovery Mode*.
2. From the Main menu, press the **Next menu** function key to display Menu 2, and then press the **System flush** function key to select the System Flush mode. The unit reminds the technician to "**Please empty the purge oil bottle prior to flushing.**"
3. Press **Start** to continue. The unit now reminds the technician to install the inline flushing adapter and remove the orifice tube or TXV valve before continuing.
4. If not already done, connect the high- and low-side service hoses to their respective service ports, and ensure that the service-port valves are open.

5. Again press **Start** to continue. The unit now displays “**Set Flush Time.**” Set the flush time by pressing and holding down the **Increase** or **Decrease** key until the desired time is shown. Press **Start** to accept the flush time shown on the screen. A minimum flush time of 30 minutes is recommended.

Important! *There must be a minimum of 12 pounds of refrigerant in the internal storage tank in order to complete the System Flush process. A message will be displayed if additional refrigerant needs to be added. Add additional refrigerant by following the procedure described in Section 3.8 Internal Tank Manual Refill.*

6. Press the **Start** key to begin flushing. The MAC2000 begins flushing the A/C system in the following manner:
 - The A/C system is first completely filled with refrigerant, during which time the screen shows “**Flushing – Charging.**”
 - The system is now flushed for the time duration set in Step 5, during which time the screen shows “**Flushing system.**”
 - After the system is flushed, all refrigerant is automatically recovered. The screen shows “**Recovering refrigerant**” during this process.
 - The flush cycle completes by draining the oil that was removed during the flushing process into the unit’s oil drain bottle (see MAC2000 Left-Side View, Page 5). The screen shows “**Draining oil**” during this process.

Important! *All oil was removed from the A/C system during the System Flush operation. Be sure that the proper amount of oil is added back into the vehicle’s A/C high side port in accordance with the vehicle manufacturer’s recommendations.*

7. The unit beeps and its red light flashes to indicate that the flushing cycle is complete. The screen now reminds the technician to remove the inline flushing adapter, and to reinstall the orifice tube or TXV valve.
8. Evacuate and then recharge the A/C system per Sections 3.4 and 3.5.

3.7 Refrigerant Management System

The MAC2000's Refrigerant Management System tracks all aspects of refrigeration usage, which can significantly help in the management of an A/C repair business. In addition, the unit's software allows a business to meet new federal regulations requiring strict records of refrigerant usage.

Refrigerant measurement during charging is extremely accurate. In the recovery mode, however, accuracy is plus or minus 3 ounces based on variations in air temperature and pressure.

Uses of the refrigerant data include:

- Improved record keeping
- Accurate determination of net profits for your business
- Reduced billing errors
- Minimized refrigerant loss from leaks and theft
- Reduced technician errors

Enter the Refrigerant Management mode as follows:

From the Main menu, press the **Next menu** function key twice to display Menu 3; then press **Refri Data** to select the Refrigerant Management Mode.

The first screen displays the following information in the “**Last job refrigerant management data**” screen:

- Date & timeDate and time the job was started
- ModeLists what job was performed: recovery, charging, vacuum, or flush
- Run timeTime it took to complete the job
- StatusDescribes whether the job was normally completed or interrupted
- RecoveredWeight of refrigerant recovered from vehicle
- ChargedWeight of refrigerant charged into vehicle
- AddedWeight of refrigerant transferred from the external source tank to the internal storage tank

Pressing **Next** displays the following data in the “**Total refrigerant management data**” screen:

- Total # Of Jobs ..Total time spent doing all jobs, and number of all jobs that were performed
- Total Recovery...Time spent doing recovery and number of times it was performed
- Total Vacuum....Time spent doing evacuation and number of times it was performed
- Total ChargeTime spent charging and number of times it was performed

- Total Flush.....Time spent flushing and number of times it was performed
- RecoveredTotal amount of refrigerant recovered
- ChargedTotal amount of refrigerant charged
- AddedTotal amount of refrigerant transferred from the external virgin tank to the internal storage tank
- Filter life leftWeight of refrigerant that can be charged before the Filter Dryer needs replaced

Pressing **Next** again displays the “**Job history**” screen, which contains the history of each job performed. A technician can press the **UP** and **Down** keys to scroll through the last 75 jobs.

Tips: *Holding down the Up or Down key speeds up scrolling.*

*The total screen can be cleared by entering the Set-up mode and selecting “**Clear totals?**”*

*Job history can be cleared by entering the Set-up mode and selecting “**Clear job history?**”*

3.8 Internal Tank Manual Refill

When the MAC2000 remains turned ON during the day, the unit automatically refills the internal tank with refrigerant from the external source tank. An operator, however, can manually add refrigerant as follows:

1. If not already done, plug the MAC2000 into a properly grounded AC outlet; set the **Power** switch to ON; then wait until the unit completes its self diagnostics. The screen will display “**Select mode**” when ready.
2. Press the **Next menu** function key to display Menu 2. Then press the **Tank refill** function key to begin the refill process.

Note: *If the tank is already filled with 12 lbs or more of refrigerant, then the message “**Tank already full**” appears.*

3. Press the **Start** key to continue. The screen will then display “**The internal tank is now being refilled.**” When the internal tank is filled, the screen displays “**Tank refill complete.**”
4. Press the **Reset** key to return to the Main menu.

3.9 System Set Up

When the MAC2000 is initially turned on for the first time, the unit automatically enters its System Set-Up mode. The unit must then be set up by following the on-screen prompts before it can be used.

To change the data that was entered during the initial set-up process, or to perform other functions such as clearing job history or recalibrating the pressure transducers, re-enter the System Set-Up mode as follows:

1. If not already done, plug the MAC2000 into a properly grounded AC outlet; set the **Power** switch to ON; then wait until the unit completes its self diagnostics. The screen will display “**Select mode**” when ready.
2. Press the **Next menu** function key to display Menu 2. Then press the **System set-up** function key.
3. Follow the on-screen prompts to enter the following data or perform the following procedures:
 - Time & Date
 - Language
 - Use Metric units (Yes or No)
 - Calibrate Pressure Transducers (remove service hoses from the unit’s Service Hose Fittings and follow on-screen prompts)
 - Elevation above sea level
 - Clear error flags
 - Clear job totals
 - Clear job history
 - Print data after every job
4. Press the **Reset** key at any time to save the settings and return to the Main menu.

3.10 Identify Refrigerant

Before performing any maintenance work a technician can determine the following information about the vehicle’s refrigerant

- Whether the refrigerant in the A/C system can or cannot be recovered
- % R-134a
- % R-22
- % R12
- % Air
- % HC (Hydrocarbons)

Perform a refrigerant identity check as follows:

1. If not already done, plug the MAC2000 into a properly grounded AC outlet; set the **Power** switch to ON; then wait until the unit completes its self diagnostics. The screen will display “**Select mode**” when ready.
2. Press the **Next menu** function key twice to display Menu 3. Then press the **Identify mode** function key.
3. Hook up the service hoses, open the A/C system’s service-port valves, and then press the unit’s **Start** key. At this time the refrigerant identifier will warm up, zero itself, and then display the message “**Analyzing sample, please wait . . .**” When complete, the results of the identification process will be displayed.
4. Press **Reset** to exit the identification screen.
5. Close service-port valves, and remove service hoses from vehicle.
6. Press **Start** to begin recovering the hoses. During the recovery process the message “**Clearing hoses, please wait . . .**” is displayed. After recovery is complete, the Main menu will appear.

3.11 Check Internal Tank for Air

When the MAC2000 remains turned ON during the day, air is automatically purged from the internal storage tank. A technician, however, can manually check and purge the internal tank of air and any other non-condensable gases as follows:

1. If not already done, plug the MAC2000 into a properly grounded AC outlet; set the **Power** switch to ON; then wait until the unit completes its self diagnostics. The screen will display “**Select mode**” when ready.
2. Press the **Next menu** function key twice to display Menu 3. Then press the **Check Tank Air** function key.
3. Press the **Start** key. The refrigerant identifier will first warm up, zero itself, and then display the message “**Analyzing sample, please wait ...**” When complete, the results of the identification process will be displayed.

4. Depending on the percentage of air found in the internal tank, perform one of the following:
 - If the display shows “**Identifier result: EXCESSIVE,**” then purge the tank by first pressing the **Reset** key to display the message “**Would you like to purge air?**” Then press the **Start** key to begin purging air. When complete, the Main menu will appear. Repeat Steps 2, 3, and 4 until the percentage of air within the internal tank is at an acceptable level.
 - If the display shows “**Identifier result: RECOVERABLE,**” then the amount of air within the tank is at an acceptable level. Press the **Reset** key to display the message “**Would you like to purge air?**” Then press the **Reset** key again to return to the Main menu.

4 Maintenance

Field maintenance of the MAC2000 is limited to the following:

- Changing the filter drier
- Tracking of refrigerant using the unit's Refrigerant Management System
- Replacing the external refrigerant source tank
- Replacing the printer paper
- Replacing the refrigerant identifier filter

All other maintenance should be performed by an authorized Bacharach Service Center (Section 5.2).

4.1 Changing the Filter Drier

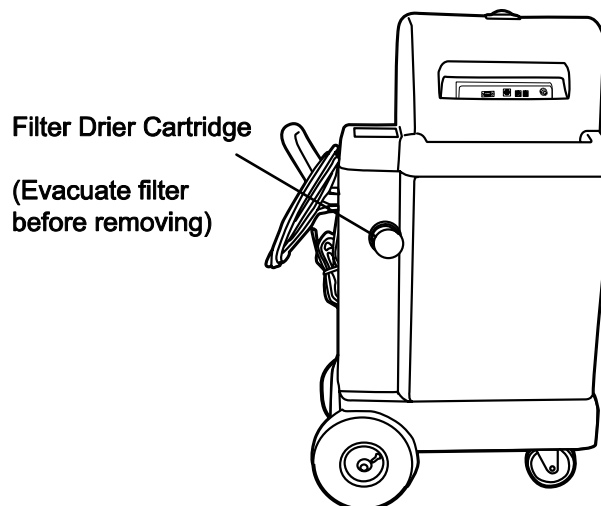

The MAC2000 has a unique filtering system that ensures the refrigerant transferred to the storage tank is clean and moisture-free. The filter drier must be changed periodically to ensure that the system will work properly.

The MAC2000 will automatically indicate when the filter needs to be changed. If the “**Change Filter**” message appears when the Recovery mode is selected, it is best to complete that job before changing the filter drier. “**Change Filter**” will be displayed on the screen whenever the recovery mode is selected until the filter has been replaced.

All refrigerant must be evacuated from the old filter before it is removed from the unit. Follow the filter change procedures carefully to minimize refrigerant loss and ensure only clean, moisture-free refrigerant is transferred into the storage tank.

Caution: *The filter drier should not be changed with the MAC2000 still connected to the vehicle. Disconnect the unit by closing the vehicle's service-port valves and disconnecting the high- and low-side hoses from the vehicle.*

1. If not already done, plug the MAC2000 into a properly grounded AC outlet; set the **Power** switch to ON; then wait until the unit completes its self diagnostics. The screen will display “**Select mode**” when ready.
2. From the Main menu, press the **Next menu** function key to display Menu 2.
3. Follow the on-screen prompts; then press the **Start** key to begin evacuating the filter.
4. When completely evacuated, follow the on-screen prompts and remove the old filter drier by unscrewing it counterclockwise. Dispose of the used filter in a proper manner.
5. Lubricate the O-rings of a new filter drier with a light grease or saliva; then hand tighten until it bottoms out.
6. Press the **Reset** key after the new filter has been installed. This will remove any air that may have entered the system during the changeover process.

4.2 Replacing the External Source Tank

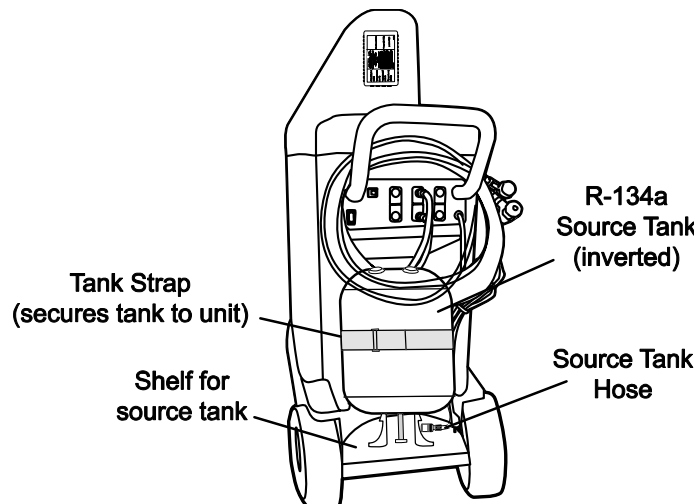

The internal storage tank contains enough refrigerant for several jobs, but it's important to replace the external source tank soon after the message “**Source Tank empty**” is displayed so that the internal storage tank isn't depleted during a charge operation.

To replace the external source tank:

1. Close tank valve; remove yellow hose from tank valve; release tank strap; then remove tank from side of unit.
2. Place a new source tank on the shelf and secure it with the tank strap. The tank strap must be set up to supply *liquid* – this usually means the tank is *inverted*.
3. Reconnect the yellow hose to the tank fitting; then open the tank valve.
4. The unit's automatic tank refill function will add refrigerant to the internal storage vessel as the unit is used. A technician may fill it immediately, however, by pressing the **Next menu** function key to display Menu 2, and then pressing the **Tank refill** function key to immediately begin filling the internal storage tank.

4.3 Replacing the Printer Paper

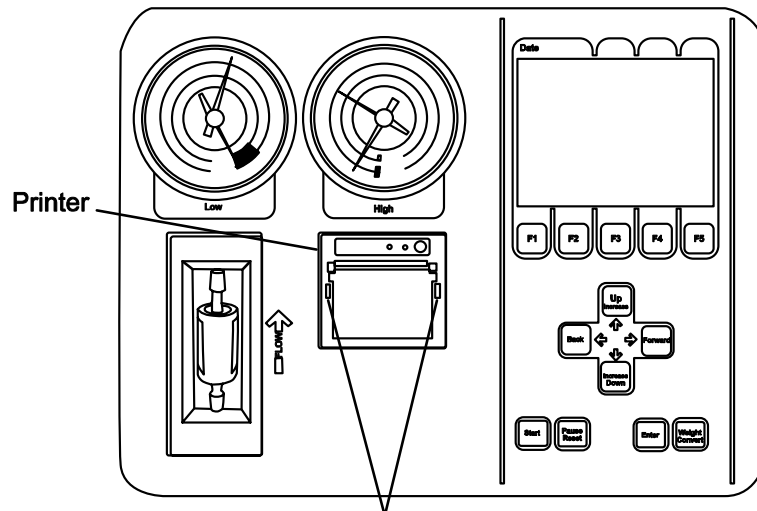

Release Printer Cover by
squeezing together these two latches

1. Open the printer cover by first squeezing together the cover's two plastic latches, and then pulling the cover forward.
2. Remove the old paper-roll core.
3. Insert the new paper roll so that it unrolls over-the-top. Then pull out several inches of paper and position the paper so that it rests against the paper cutter.
4. Close the printer cover.
5. Press and hold the feed button to ensure that the paper feeds properly; then tear off the excess paper.

4.4 Replacing the Refrigerant Identifier Filter

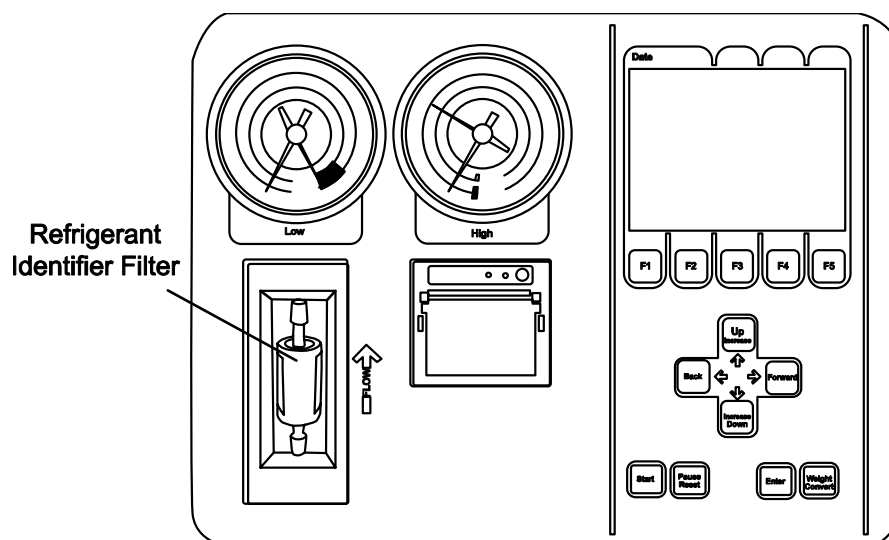

Caution: Visually inspect the Refrigerant Identifier Filter every day. If it begins to turn red, replace it immediately! You risk damaging the identifier sensor if the filter is not replaced.

The refrigerant identifier filter is located on the control panel, directly under the Low Side pressure gauge. The filter's function is to protect the refrigerant identifier sensor from contaminants. **When this filter starts to develop red spots, replace the filter immediately!**

1. Remove the filter from its holder; then remove the tubing from each end.
2. Position the new filter so that its flow-arrow points in the same direction as the flow-arrow on the control panel.
3. Attach the tubing to the new filter, and press the filter back into its holder.

5 Parts and Service

5.1 Parts

| | |
|---|-----------|
| Model MAC2000, 115VAC 50/60 Hz | 2000-4200 |
| Model MAC2000, 220–240VAC, 50/60 Hz | 2000-4206 |
| Bottle, Oil Drain..... | 2055-0150 |
| Filter Drier | 2037-0030 |
| Filter, Refrigerant Identifier | 2068-0010 |
| Power Cord (for Snap-Shot Data Transmitter) | 2066-0040 |
| Printer..... | 2017-0080 |
| Printer Paper..... | 2075-0060 |
| Sensors (for Snap-Shot Data Transmitter): | |
| Anemometer (air flow) | 2064-0010 |
| Temperature (blue) | 2062-0020 |
| Temperature (red) | 2062-0010 |
| Service Coupler – Red (High Side) | 2022-1240 |
| Service Coupler – Blue (Low Side) | 2022-1230 |
| Service Hose – Red (High Side) | 2035-0170 |
| Service Hose – Blue (Low Side) | 2035-0180 |
| Snap-Shot Data Transmitter..... | 2001-0001 |

5.2 Service Centers

Service and replacement parts can be obtained by contacting a Bacharach Service Center at the following locations:

California

7281 Garden Grove Blvd.,
Suite H
Garden Grove, CA 92841
Phone: 714-895-0050
Fax: 714-895-7950
E-mail: calservice@bacharach-inc.com

Indiana

8618 Louisiana Place
Merrillville, IN 46410
Phone: 219-736-6178
Fax: 219-736-6269
E-mail: indservice@bacharach-inc.com

New Jersey

7300 Industrial Park
Rte. 130, Bldg. 22
Pennsauken, NJ 08110
Phone: 856-665-6176
Fax: 856-665-6661
E-mail: njservice@bacharach-inc.com

Pennsylvania

621 Hunt Valley Circle
New Kensington, PA 15068
Phone: 724-334-5051
Fax: 724-334-5723
E-mail: help@bacharach-inc.com

Texas

5151 Mitchelldale, B-4
Houston, TX 77092
Phone: 713-683-8141
Fax: 713-683-9437
E-mail: txservice@bacharach-inc.com

Canada

Bacharach of Canada, Inc.
151 Bentley Street Unit #6
Markham, Ontario L3R 3X9 Canada
Phone: 905-470-8985
Fax: 905-470-8963
E-mail: bachcan@idirect.com

México

Bacharach de México
Playa Regatas No. 473 Tercer Piso
Col. Militar Marte
Delegación Iztacalco, 08830
México D.F.
México
Phones: 011-5255-5634-7740
011-5255-5634-7741
FAX: 011-5255-5634-7738
E-mail: bacharach@prodigy.net.mx

Denmark

Bacharach Instruments Int'l
P.O. Box 44
39 Lindegade
DK 6070 Christiansfeld
Denmark
Phone: 011/45 74 563171
Fax: 011/45 74 563178
E-mail: mail@bacharach.dk

Europe

Bacharach Europe
Sovereign House, Queensway
Leamington Spa
Warwickshire CV31 3JR
England
Phone: (01926) 338111
Fax: (01926) 338110



World Headquarters
621 Hunt Valley Circle, New Kensington, PA 15068-7074
Ph: 724-334-5000 • Fax: 724-334-5001 • Toll Free: 1-800-736-4666
Website: www.bacharach-inc.com • E-mail: help@bacharach-inc.com